

## Atmega32 AVR Modular Development Board

If you are learning microcontrollers or want to quickly develop embedded solution based on standard AVR core, this board will help you quick start with the application by giving you access to everything required to run the Atmega32 microcontroller.

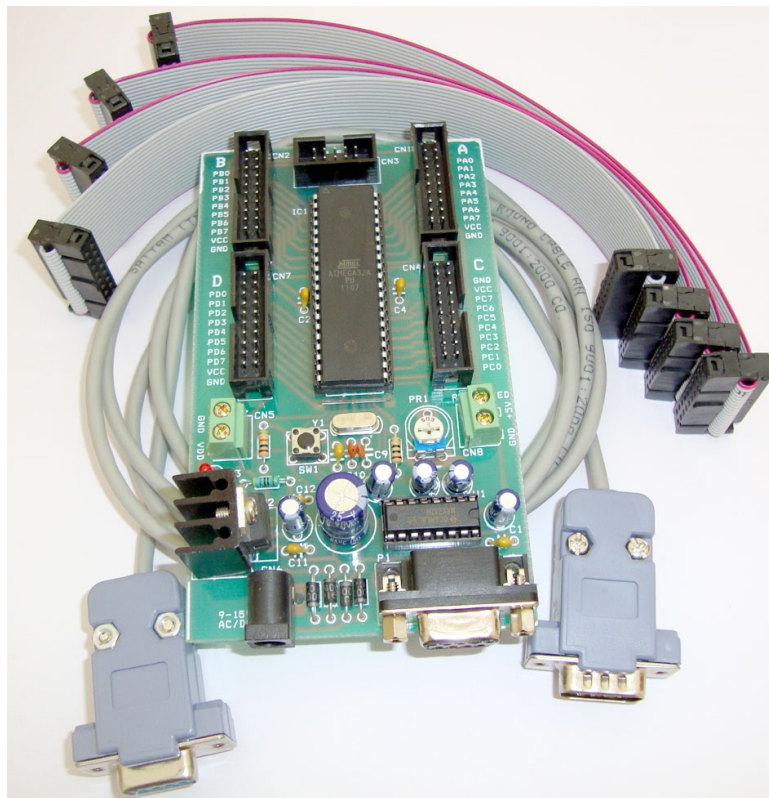

Low cost ISP programmer can be bought separately that will allows loading program for Atmel AVR chips through USB port.

### Features

- ATMEGA32 chip with ISP capability included
- All IO Pins are output to 20 pin Box Header for connecting various interfaces.
- OnBoard 1 Amp Power supply regulator based on LM7805+Diode Bridge
- RS232 Communication Port based on MAX232.
- ISP Port for In-Circuit Programming (Programmer to be purchased separately)



## Board Overview

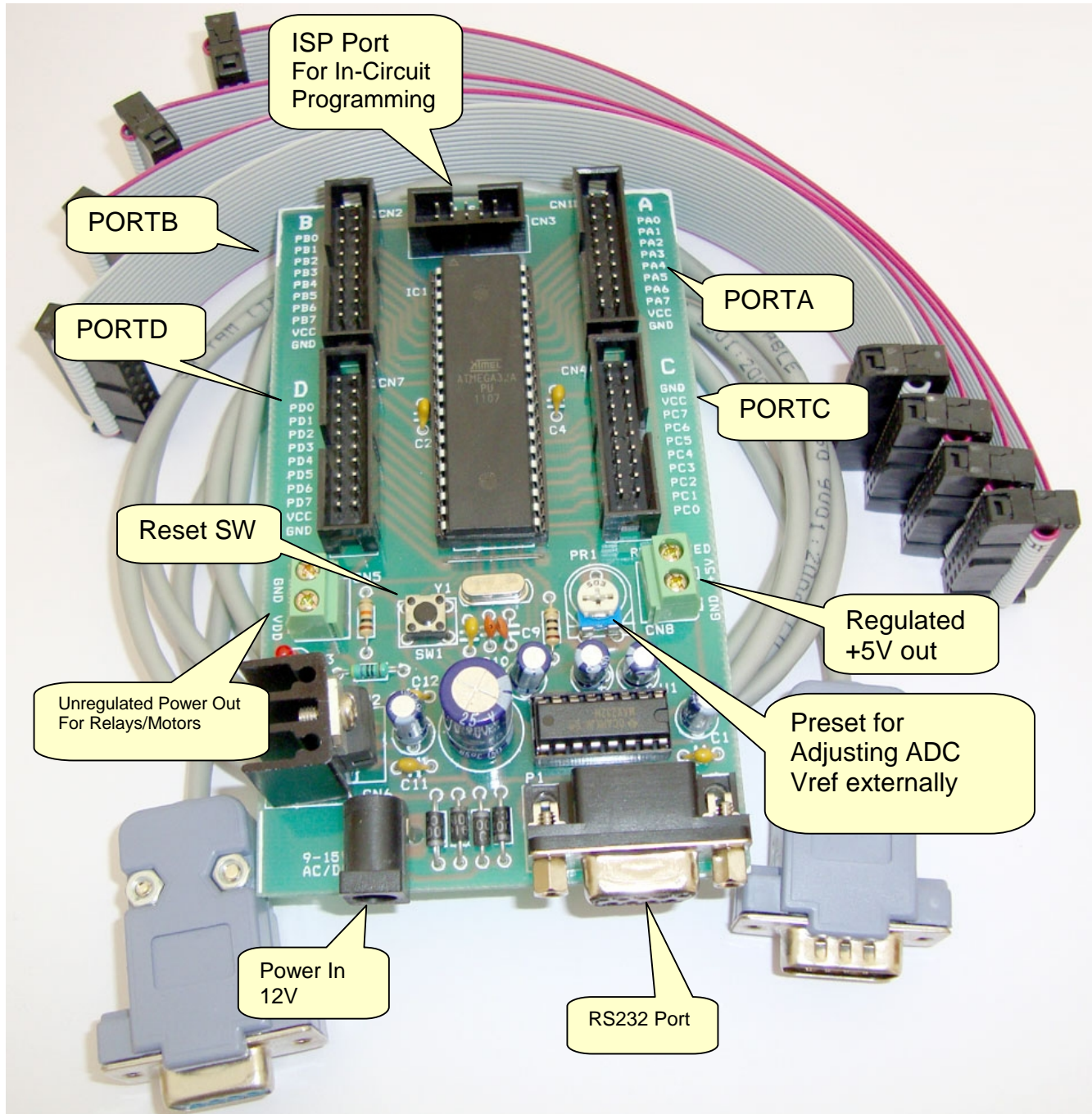

## Our Package Includes

- Development Board with ATmega32 Chip (Fully Assembled & Tested covering 1 Year Warranty)
- 4x 20 pin FRC cables for port connections
- Serial Cable for RS232 Communication

# Board Schematic

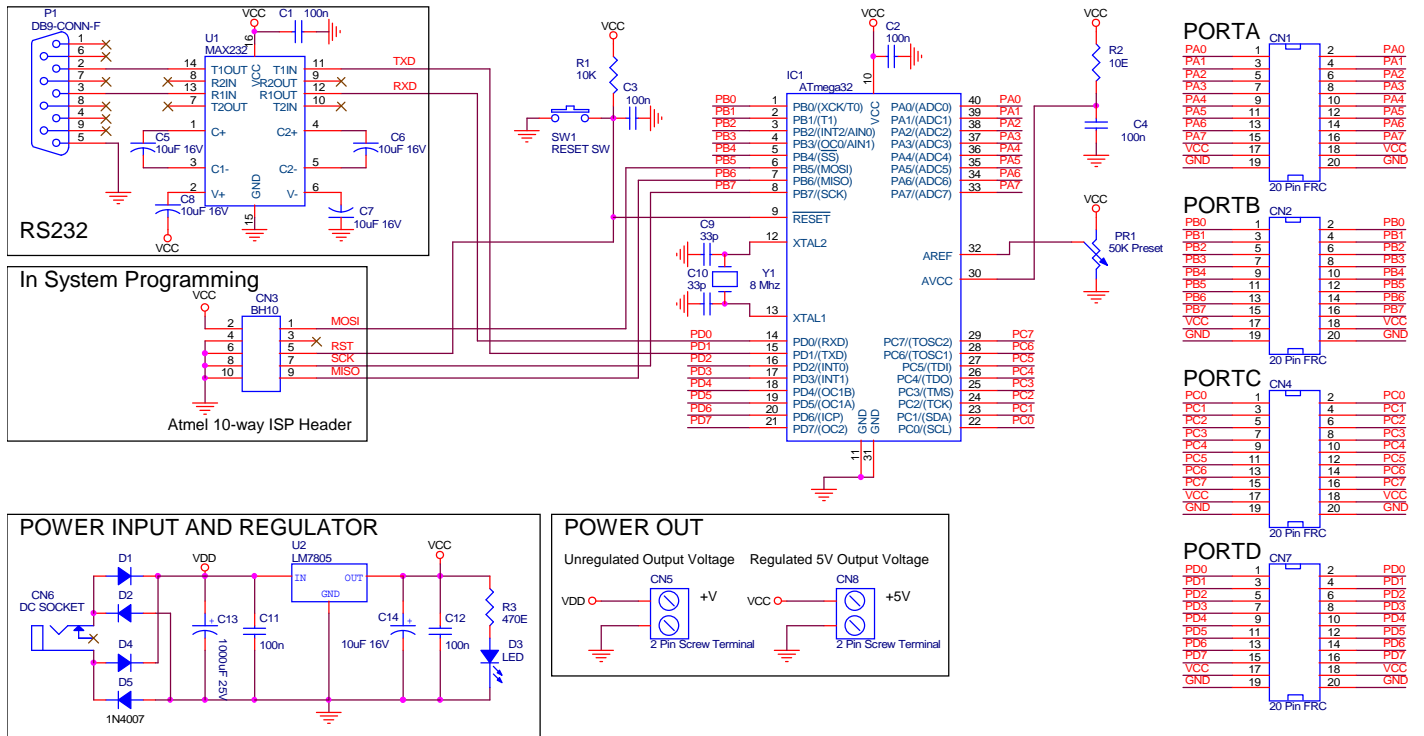

<b>Sunrom Technologies</b>		<a href="http://www.sunrom.com">http://www.sunrom.com</a>	
Title: AVR Development Board			
Code: AVR-M32		Rev: 2	
Date: Tuesday, November 28, 2006		Sheet 1 of 1	

## Using the Board

### 1<sup>st</sup> Give Power to board

You will need to power the board from a DC power supply Adapter. You can use any general purpose 12V/500mA adapter to power the board. Alternately you can use a 12V step down transformer to board the board. Depending on the application you wish to develop you can also use 12V/1Amp DC Adapter if your interfacing units like LCDs, Relays and Displays would consume more current.

### 2<sup>nd</sup> Write Code & Program the IC AVR

The IC on board can use a In-Circuit Programmer like sunrom's Model: 1138 for in-circuit programming without removing the IC from socket. When programming is finished the IC will automatically be put in run mode.



#### AVR ISP USB Programmer

Model: 1138

Product's Page

<http://www.sunrom.com/p-1072.html>

### 3<sup>rd</sup> Connect Interfacing Units as required by your application

We have many interfacing units like ADC, LCDs, Seven Segments, Motor Control and such which you can connect and use with development board.

Visit this page for complete list

<http://www.sunrom.com/interfacing-units>

Visit this page for complete list  
<http://www.sunrom.com/interfacing-units>

Model	Description
5000-0009	<b>Eight Channel ADC using ADC0808</b> Features Adjustable VREF pot between 0 to 5V Eight Channel of Analog Voltage...
1158	<b>ADC/DAC Board – I2C Interface</b> This board has four analog inputs and one analog output, controlled through...
5000-0010	<b>Eight Relay Output Board</b> Provided as fully assembled tested product
5000-0003	<b>16x2 LCD Display Board</b> Connected in a 4-bit interface, provided as fully assembled tested product with...
5000-0006	<b>Eight Digit Seven Segment Display Board</b> Requires two 8 bit ports. One for display selection and another for display...
5000-0007	<b>4x4 Matrix Keypad</b> Fully assembled tested product with schematic
5000-0005	<b>Dual Stepper Motor Driver Board using ULN2803</b> The ULN2803 output Board allows higher voltage and current devices to be...
5000-0008	<b>Eight LED Board</b> Fully assembled tested product with schematic
5000-0004	<b>Eight Switches Board</b> Fully assembled tested product with schematic
5000-0028	<b>Screw Terminal Board</b>