

Dimensions mm (In.)

Specifications:

- Rating:
 - Voltage: 30 VAC (R.M.S.)
 - Current: 1.0 Ampere Maximum Per Contact
 - Temperature: -55°C to +85°C
- Electrical Characteristic:
 - Contact Resistance: 30 Milliohms Maximum Initial
 - Insulation Resistance: 1,000 M ohms Minimum
 - Dielectric Withstanding Voltage: 500 VAC
 - Capacitance: 2 Picofarads Maximum at 1KHZ
- Materials
 - Shell: Copper Alloy Tin Lead Plated
 - Housing: PBT, glass Filled, 130°C, UL 94V-O Rated
 - Contact: Copper Alloy Gold Plated 5u"
 - Insulator: White Color

- Recommended PC Board Thickness of 1.57mm
- Recommended Panel Thickness of 2.67mm Maximum

General Tolerance:

x.	±0.38
.x	±0.25
.xx	±0.13
.xxx	±0.05

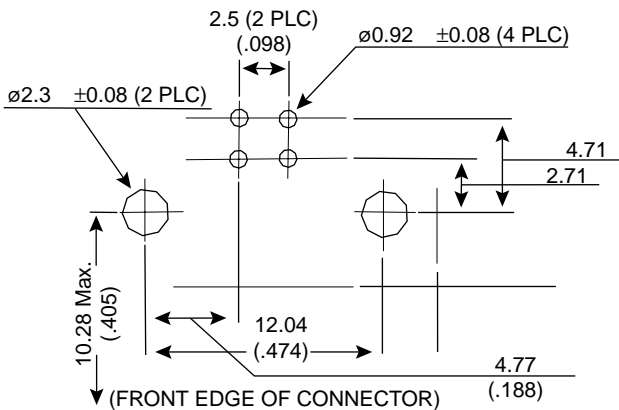

FIGURE A: PCB FOOTPRINT FOR RECEPTACLE (THROUGH-HOLE)